

(Abb. 1)

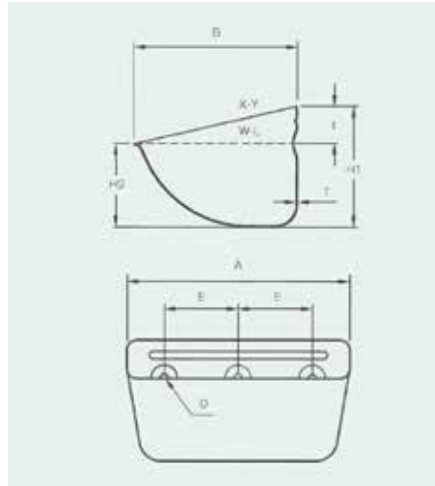

SUPER STARCO
STAHL
ELEVATORBECHER



TECHNISCHE SPEZIFIKATION - SUPER STARCO STAHL ELEVATORBECHER

Typ	A	B	H1	H2	T	Stahl	Inhalt (W-L)	Inhalt (X-Y)	Anzahl Löcher	D	E	l	Max. Becher/m
Einheit	mm	mm	mm	mm	mm	kg	l	l		mm	mm	mm	Stck.
SPS 80 - 80	85	80	58	39	1,0	0,11	0,18	0,21	2	8,0	43	16	15,00
SPS 100-90	106	89	66	45	1,0	0,12	0,25	0,33	2	8,5	50	20	14,00
SPS 100-100	105	97	78	45	1,0	0,18	0,29	0,42	2	8,5	50	25	12,00
SPS 120-100	125	105	77	53	1,0 / 1,5	0,22 / 0,33	0,44	0,58	2	8,0	67	25	12,00
SPS 140-110	146	112	91	40	1,5	0,43	0,41	0,76	2	8,5	70	25	10,5
SPS 130-120	138	120	90	62	1,2 / 1,5	0,30 / 0,38	0,65	0,83	2	8,5	70	22	10,50
SPS 140-120	146	120	88	58	1,5	0,32	0,65	0,87	2	8,5	70/86(#)	25	10,50
SPS 160-140	166	147	112	78	1,5	0,55	1,20	1,58	2	8,5	100	30	8,60
SPS 180-140	187	147	112	78	1,5	0,61	1,35	1,75	2	8,5	100	30	8,60
SPS 200-150	205	150	112	77	1,5	0,77	1,53	2,00	2	9,0	100/102(#)	32	8,60
SPS 230-160A	233	160	122	85	1,5 / 2,0	0,86 / 1,15	2,05	2,72	3	9,0	70	32	8,00
SPS 230-160B	233	160	122	85	1,5 / 2,0	0,86 / 1,15	2,05	2,72	2	10,5	120	32	8,00
SPS 240-160A	247	165	130	92	2,0 / 3,0	1,35 / 2,00	2,37	3,03	3	10,5	70/77(#)	35	7,40
SPS 240-160B	247	165	130	92	2,0 / 3,0	1,35 / 2,00	2,37	3,03	2	10,5	140	35	7,40
SPS 240-160C	247	165	130	92	2,0 / 3,0	1,35 / 2,00	2,37	3,03	2	10,5	120	35	7,40
SPS 260-165	262	165	130	92	2,0 / 3,0	1,38 / 2,10	2,55	3,28	3	10,5	77/80(#)	35	7,40
SPS 280-165	289	167	132	93	2,0 / 3,0	1,55 / 2,32	2,95	3,78	3	10,5	80	38	7,40
SPS 300-165A	308	165	135	94	2,0 / 3,0	1,65 / 2,50	2,90	3,88	3	9,0	100/104(#)	36	7,20
SPS 300-165B	308	165	135	94	2,0 / 3,0	1,65 / 2,50	2,90	3,88	3	11,0	100	36	7,20
SPS 330-165	340	165	135	97	2,0 / 3,0	1,90 / 2,85	3,50	4,40	3	11,0	110/120(#)	38	7,20
SPS 350-165/A	360	165	135	94	2,0 / 3,0	2,12 / 3,20	3,65	4,50	4	9,0	90	38	7,20
SPS 350-165/B	360	165	135	94	2,0 / 3,0	2,12 / 3,20	3,65	4,50	3	11,0	120	38	7,20
SPS 230-170	235	170	132	93	2,0	1,40	2,40	3,09	2	11,0	120	35	7,00
SPS 200-180	204	182	140	98	2,0	1,28	2,17	2,84	2	11,0	110	44	7,00
SPS 260-180	270	188	140	96	2,0	2,00	3,20	4,10	3	11,0	80	45	7,00
SPS 280-180	290	185	140	97	2,0 / 3,0	1,70 / 2,55	3,30	4,40	3	11,0	80	38	7,00
SPS 300-180/A	308	182	140	95	2,0 / 3,0	1,80 / 2,70	3,50	4,50	3	9,0	100/104(#)	36	7,00
SPS 300-180/B	308	182	140	95	2,0 / 3,0	1,80 / 2,70	3,50	4,50	3	11,0	100	36	7,00
SPS 330-180	340	182	140	98	2,0	2,00	4,00	5,20	3	11,0	110/120(#)	38	7,00
SPS 350-180/A	362	182	140	98	2,0 / 3,0	2,10 / 3,15	4,20	5,40	4	9,0	90	38	7,00
SPS 350-180/B	362	182	140	98	2,0 / 3,0	2,10 / 3,15	4,20	5,40	3	11,0	120	38	7,00